

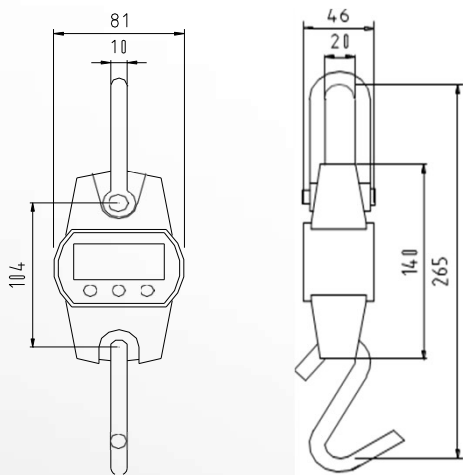

Model **PRECISO OCS-L** series

Digital Hanging Scale



Features:

- ❖ Weighing units: kg, lb & n
- ❖ Battery power: 3xAA (included)
- ❖ With tare in/tare out, hold, low voltage auto power-off, battery supervision, overload alarm functions
- ❖ Net. Weight: 650g
- ❖ Die-casting aluminium enclosure
- ❖ Stainless steel shackle and steel hook
- ❖ Water-proof panel button (KEYBOARD)
- ❖ 20mm LCD display
- ❖ Actual total weight (690g without packaging) & (840g with packaging)

Optional:

- ❖ Handheld handle
- ❖ St/steel suspended bowl

Specifications:

Accuracy class	Equivalent to OIML III
Tare range	100% F.S.(FULL SCALE)
Zero range	4% F.S.
Safe overload	120% F.S.
Ultimate overload	400% F.S.
Overload alarm	100% F.S.+9e
Battery life	more than 100h
Temperature range	-10°C~40°C
Accessories	3 X AA batteries, operating manual
Hook	stainless steel hook
Shackle	stainless steel shackle

Capacity	30kg	60kg	150kg	300kg
Graduation	5g	10g	20g	50g
Min. Weight	200g	400g	1000g	2000g